

Load-sensing control block of sandwich plate design SP-08

RE 64139

Edition: 07.2015

Replaces: 02.2014



HAD 7345

- ▶ Series 2X
- ▶ Maximum operating pressure
 - On the pump side 250 bar
 - On the actuator side 300 bar
- ▶ Maximum flow
 - On the pump side 75 l/min
 - On the actuator side 50 l/min

System

- ▶ Load pressure-independent flow control
 - Open center for fixed displacement pump
 - Closed center for variable displacement pump

Design

- ▶ Sandwich plate design
 - Inlet plate
 - Up to 10 directional valves
 - End plate
- ▶ Types of actuation
 - Mechanical (hand lever)
 - Hydraulic
 - Electro-magnetic: Switchable, proportional

Flow

- ▶ Load pressure-compensated
- ▶ High repetition accuracy
- ▶ Low hysteresis
- ▶ Adjustable by means of variable orifice
(repeated use up to 5 times)

Pressure limitation

- ▶ With primary pressure relief valve in the inlet plate
- ▶ Pilot operated pressure relief/anti-cavitation valve in the directional valve/actuator ports

Fields of application

- ▶ Truck applications
- ▶ Construction machines
- ▶ Drilling machinery
- ▶ Agricultural machinery
- ▶ Aerial work platforms
- ▶ Municipal vehicles
- ▶ Cranes
- ▶ Stationary applications

Contents

Function	2
Technical data	4
Characteristic curve	5
Ordering code	6
Order examples	9
Open center inlet plates	11
Closed center inlet plates	12
Directional valves	15
End plates	18
Line connections	18
Dimensions	19
Accessories	25

Function

Control block SP-08

The directional valves are switchable valves or proportional valves according to the load-sensing principle. They can be operated mechanically, hydraulically or electro-magnetically.

Actuator control with electro-magnetic actuation

The position of main spool (2) relative to housing (1) determines the direction and the amount of flow fed to the actuator ports (A or B).

In the non-operated condition, the main spool is centered by compression springs (7). There is no connection between P and A or B.

When the electric control current exceeds the value of the spring force, the main spool starts to move from its central position and the connection P → A or P → B opens.

Releasable check valve

Optionally integrated pilot operated check valves (5) can be used for the leakage oil-free isolation of the actuators.

They can be installed in one actuator line (B) or in both actuator lines.

Flow limitation

The maximum flow can be set mechanically and individually by means of a variable orifice (3).

Pressure limitation

Pressure valves with combined anti-cavitation function (4) protect actuator ports A and B from pressure peaks and negative load cases.

Section pressure compensator

In the central position of the main spool, the connection from P to actuator ports A and B is closed. In this operating state, pressure compensator spool (9) is shifted by the pump pressure to the left against spring (10).

If a function is required, the LS pressure is directed via the main spool to the spring chamber and shifts the pressure compensator spool to the right into the controlled position. The flow is kept constant even when several actuators with different load pressures are operated in parallel.

Sections, symbols

▼ **SP-08 directional valve with electro-magnetically switchable actuation (C2) and pressure relief/anti-cavitation valve in actuator port B (A...)**

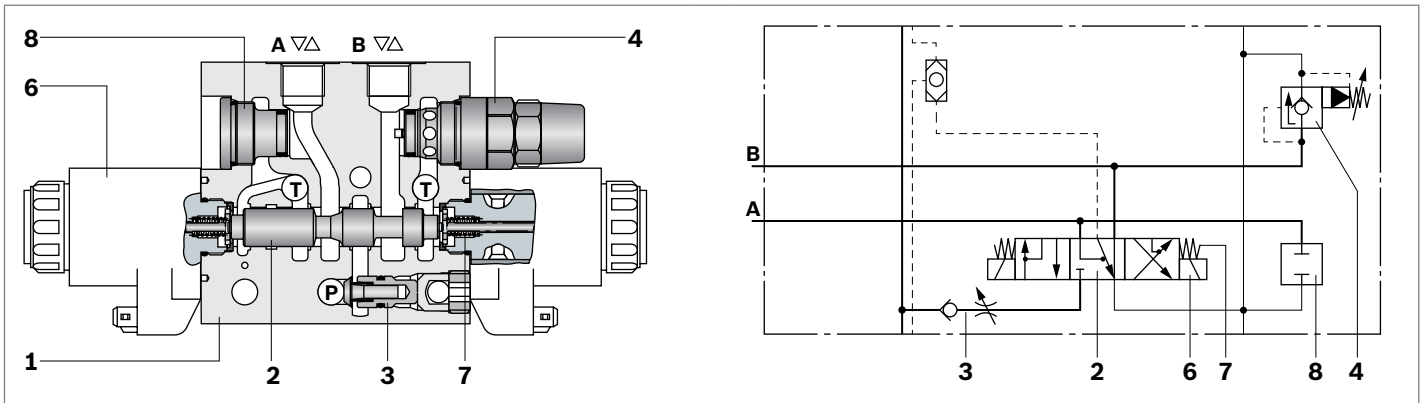

▼ **SP-08 directional valve with electro-magnetically switchable actuation (C2) and pilot operated check valves (S)**

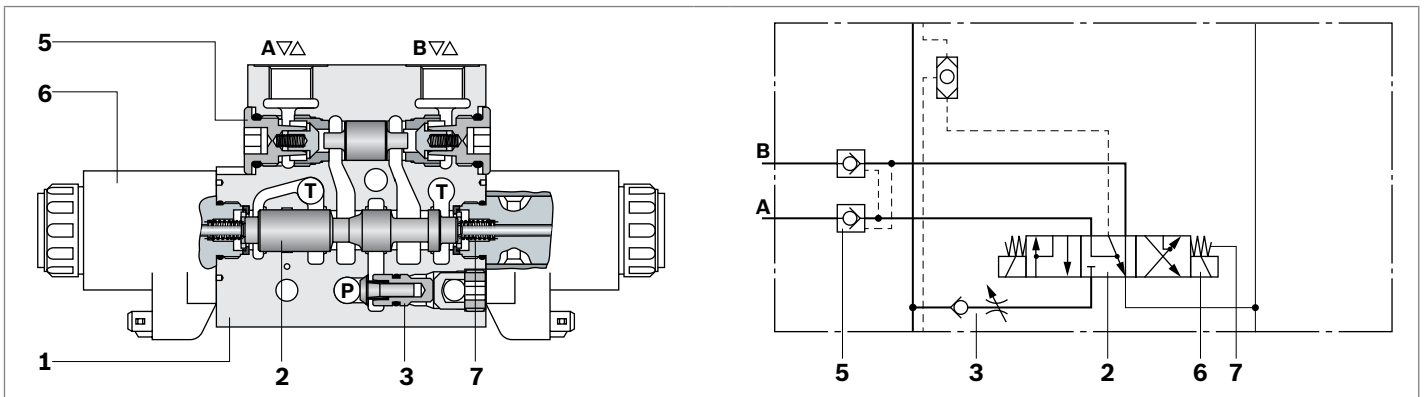

▼ **SP-08 directional valve with electro-magnetic proportional actuation (P5), section pressure compensator and pressure relief/anticavitation valve in actuator ports A and B (H...)**

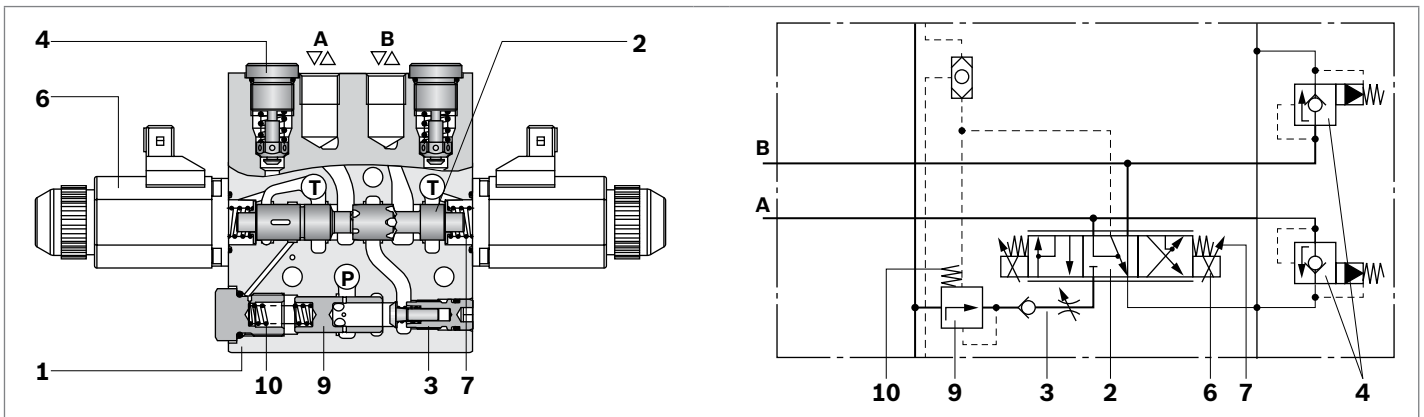

- | | |
|---|--------------------------------|
| 1 Housing | 5 Pilot operated check valves |
| 2 Main spool | 6 Solenoid |
| 3 Variable orifice with load holding function | 7 Compression spring |
| 4 Pressure relief/anti-cavitation valve | 8 Plug screw |
| | 9 Pressure compensator |
| | 10 Pressure compensator spring |

Connections	
P	Pump
T	Tank
A, B	Actuators

Technical data

general			
Weight			
Inlet plate	With 3-way pressure compensator P	kg	2.3
	With 2-way pressure compensator M, H	kg	5.2
	Without pressure compensator J, G	kg	4.9
Directional valve	With manual actuation	kg	1.8 to 2.3
	With hydraulic actuation	kg	2.2
	With electro-magnetic actuation	kg	3.0 to 3.5
End plate	LA (without mounting bracket)	kg	0.2
	LU (without mounting bracket)	kg	0.4
	Mounting bracket F, additionally	kg	0.1
	SV (with seat valve)	kg	3.3
Installation position			Any
Type of connection			Pipe thread according to ISO 228/1
Ambient temperature range	θ	°C	-20 to +80
		°C	-20 to +60 with electro-magnetic actuation
Priming			RAL 5010
hydraulic			
Maximum operating pressure at port	P, M, X, LS	bar	250
	A, B	bar	300
	T	bar	20
Nominal pressure p_{nom}		bar	250
Maximum pilot pressure at port	a, b	bar	30
Maximum flow at port	P	l/min	75
Maximum flow	Mechanical, hydraulic	l/min	50 ¹⁾
	Electro-magnetically switchable	l/min	30 ¹⁾
	Electro-magnetically proportional	l/min	25 ¹⁾
Recommended hydraulic pilot control units	Type		2TH6, control curve 06 (data sheet 64552)
	Type		2TH6R, control curve 06 (data sheet 64551)
	Type		4TH6, control curve 06 (data sheet 64555)
Hydraulic fluid			Mineral oil (HL, HLP) according to DIN 51524, other hydraulic fluids, such as HEES (synthetic esters) according to VDMA 24568, as well as hydraulic fluids as specified in data sheet 90221, at request
Hydraulic fluid temperature range θ		°C	-20 to +80
Viscosity range	ν	mm ² /s	10 to 380
Maximum admissible degree of contamination of the hydraulic fluid, cleanliness class according to ISO 4406 (c)			Class 20/18/15, for this we recommend a filter with a minimum retention rate of $\beta_{10} \geq 75$
Leakage A, B → T at an operating pressure of 150 bar	Standard	cm ³ /min	45
	With isolator valve	cm ³ /min	2

¹⁾ Greater flows on request

electric (sandwich plate design)				
Switching solenoid		Type	GZ 45, see data sheet 23178	
Proportional solenoid				
Control type			Electro-magnetically, directly	
Relative duty cycle			100 % duty cycle	
Protection class			IP 65	
Plug-in connection			AMP Junior Timer, 2-pole	
Solenoid voltage	U_{nominal}	V	12	24
Solenoid current (regulated)	I_{max}	A	2.3	1.5
Coil resistance at 20 °C	R_L	Ω	3.5 to 3.75	9.6 to 10.2
Coil resistance at 80 °C	R_L	Ω	≤ 4.8	≤ 12.8
Inductivity with nominal stroke (50 Hz)		mH	≈ 87	≈ 220
Current proportional range	I_{prop}	A	0.5 to 2.3	0.25 to 1.5
Dither amplitude (A, B)		A	0.75 ± 0.25	0.48 ± 0.2
Dither frequency (A, B)		Hz	120 ± 5	
Dither form of the current command value (A, B)			Triangular signal	

Notice

- ▶ For applications outside these parameters, please consult us!
- ▶ The technical data was determined at a viscosity range of $\nu = 41 \text{ mm}^2/\text{s}$ and a temperature of $\theta = 50 \text{ °C}$.
- ▶ For further information on the proper handling of control blocks by Bosch Rexroth, please refer to our operating instructions 64025-B "Control blocks for mobile applications".

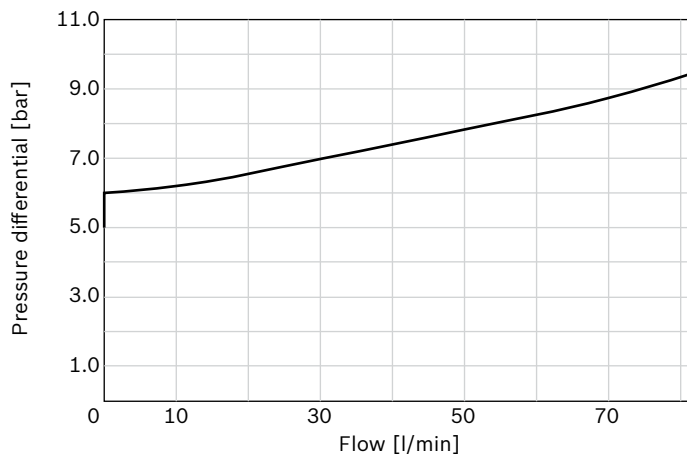
Characteristic curve
▼ Flow resistance (standard compression spring 5.5 bar)
PE → T (DF = 5.5 bar)

Ordering code

Information on the name plate

The ordering code serves to specify the technical features and requirements. The Rexroth distribution organization derives a short type as well as a material number from the ordering code.

▼ Example of a short type of the SP-08 control block with three directional valves

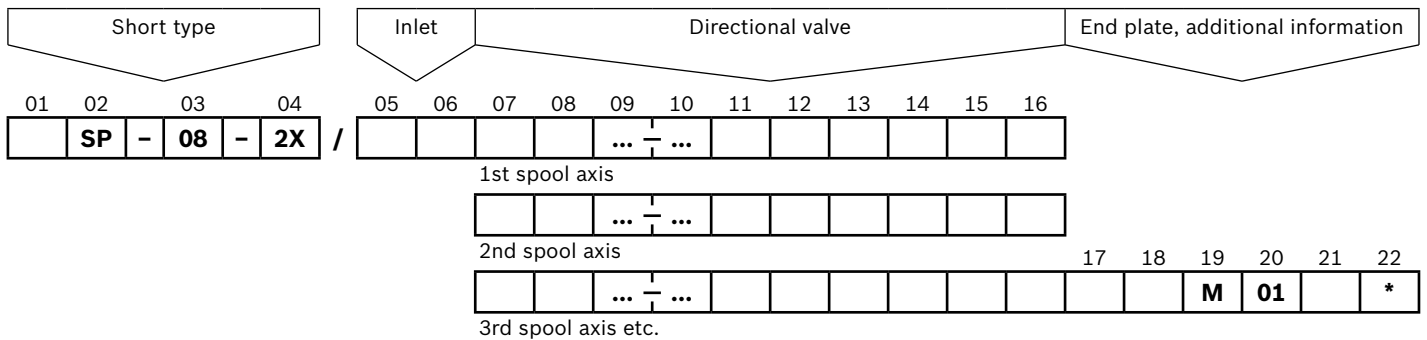
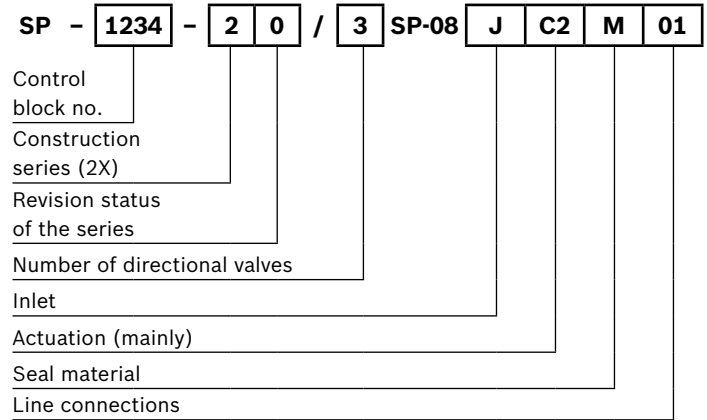

Short type

01	Total number of spool axes 1 to 10	
02	SP series	SP
03	Size 08	08
04	Series 20 to 29 (unchanged installation and connection dimensions)	2X

Inlet plate

05	Open center	With 3-way pressure compensator	P
	Closed center	Without shuttle valve, without pressure compensator	J
		With shuttle valve, without pressure compensator	G
		With shuttle valve, with 2-way pressure compensator	H
		With priority valve	V
		Adapter plate for M4-12 directional valves (only with primary pressure limitation)	L8
06	Without primary pressure limitation function (retrofitable), with plug screw, without measuring port	Q	
	With primary pressure limitation function, without measuring port (pressure to be specified in bar, 3-digit)	...	

Directional valves

07	Variable orifice with load holding function	F
	Section pressure compensator and variable orifice with load holding function	S

Spool type

08	Main spool E ¹⁾	E
	Main spool J ¹⁾	J

Flow

09	Actuator port A (to be specified in l/min, 3-digit)	...
10	Actuator port B (to be specified in l/min, 3-digit)	...

Actuation

11	Mechanical, spool end with tongue ²⁾	Z1
	Mechanical, encapsulated lever	R5
	Mechanical, with 2-axis lever ^{2), 3)}	R9
	Hydraulic	H2
	Electro-magnetically proportional	P5
	Electro-magnetically switchable	C2

Supply voltage, to be specified for C2 and P5 actuation

12	24 Volts ⁴⁾	1
	12 Volts ⁴⁾	3

Manual actuation disposition for versions Z1, R5, R9

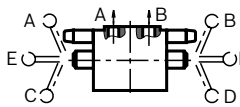
13		On connection side A , lever upwards (preferred)	A
		On connection side B , lever upwards	B
		On connection side A , lever downwards	C
		On connection side B , lever downwards	D
		On connection side A , lever forwards	E
		On connection side B , lever forwards	F

Spool return with versions Z1, R5, R9

14	By means of spring	A2
	By means of spring, spool position 2 with detent	B2
	By means of spring, spool position 1 with detent	C2
	By means of spring, spool positions 1, 2 with detent	D2

Secondary valves at actuator ports A and B

15	Without secondary valve (not retrofittable)	Z
16	Without secondary valve (retrofittable), with plug screw	Q
	Pressure relief/anti-cavitation valve, adjustable (pressure to be specified in bar, 3-digit)	A...
	Pressure relief/anti-cavitation valve, not adjustable (pressure to be specified in bar, 3-digit) ⁵⁾	H...
	Pilot operated check valve (if there is only one pilot operated check valve, it is installed at actuator port B – ordering code ZS)	S
	Float function with hydraulic detent, one-sided (at actuator port A – ordering code AZ)	A
	Pilot operated check valves with split opening spool, on both sides ⁶⁾ (float function – ordering code BB)	B

¹⁾ Symbols and preferred types see page 15

²⁾ Only lever positions **A** or **B** are possible

³⁾ **R9** can not be combined with section pressure compensator **S**.

⁴⁾ Mating connectors are not included in the scope of delivery and must be ordered separately, see data sheet 08006 and page 25

⁵⁾ Only for directional valves with pressure compensator **S**, preferred pressure adjustment see page 16

⁶⁾ Pilot operated check valves with split opening spool (float function) **BB** only in connection with end plate **SV**

8 **SP-08** | Control block
Ordering code

End plate

17	End plate ⁷⁾	LA
	End plate with LS connection	LS
	End plate with internal tank connection ⁸⁾	LU
	End plate with seat valve ¹⁰⁾	SV

Additional details

18	With mounting bracket (only in connection with end plates LA and LU)	F
19	NBR seals, suitable for mineral oil (HL, HLP) according to DIN 51524	M
20	Line connections as pipe thread according to ISO 228/1	01

SO number

21	Aluminum-free	-450
----	---------------	-------------

22	Further details in the plain text	
----	-----------------------------------	--

⁷⁾ Up to a return flow volume of 15 l/min.

⁸⁾ For a return flow volume of 15 l/min. or more

Order examples

Open center control block

Example – 2-fold control block of sandwich plate design
– Fixed displacement pump $q_{V \max} = 75 \text{ l/min}$

Inlet – Open center with primary pressure relief valve, set to 250 bar

1st spool axis – With variable orifice and load holding function
– Spool symbol **J**, flow in A and B 30 l/min
– Type of actuation: Mechanic with encapsulated hand lever on side A
– Spool return by means of spring
– Plug screw on actuator port A (secondary valves can be retrofit)
– Pressure relief/anti-cavitation valve at actuator port B, set to 210 bar

2nd spool axis – With variable orifice and load holding function
– Spool symbol **E**, flow in A and B 30 l/min
– Type of actuation: Mechanic with encapsulated hand lever on side A
– Spool return by means of spring
– Pilot operated check valves on A and B side

End plate – End plate **LA** and mounting bracket
– NBR seals, pipe thread connections

Ordering code:

Inlet plate

01	02	03	04	05	06
2	SP	-	08	-	2X / P 250

1st spool axis

07	08	09	10	11	12	13	14
F	J	030-030	R5	A	A2	Q	H210

2nd spool axis

07	08	09	10	11	12	13	14
F	E	030-030	R5	A	A2	S	S

End plate, additional information

15	16	17	18
LA	F	M	01

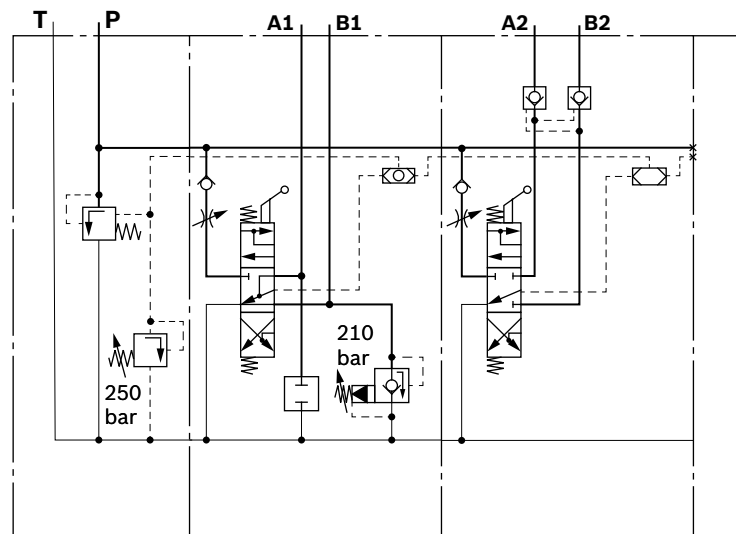

Closed center control block of sandwich plate design

- Example** – 3-fold control block of sandwich plate design
– Variable displacement pump $q_{vmax} = 75$ l/min
-
- Inlet plate** – Closed center with 2-way pressure compensator with LS shuttle valve, primary pressure limitation function, retrofittable
-
- 1st spool axis** – With variable orifice and load holding function
– Spool symbol **E**, flow in A and B 30 l/min
– Type of actuation: Hydraulic
– Without secondary valve (low housing)
-
- 2nd spool axis** – With variable orifice and load holding function
– Spool symbol **E**, flow in A and B 30 l/min
– Type of actuation: Electro-magnetically proportional, 24 V
– Electrical connection AMP type Junior Timer
– Plug screw on actuator port A (secondary valves can be retrofit)
– Secondary valves at actuator port B, set to 210 bar
-
- 3rd spool axis** – With variable orifice and load holding function
– Spool symbol **J**, flow in A and B 30 l/min
– Type of actuation: Electro-magnetically switchable, 24 V
– Electrical connection AMP type Junior Timer
– Pilot operated check valves on A and B side
-
- End plate** – End plate **LA** and mounting bracket
– NBR seals, pipe thread connections

Ordering code:

Inlet plate

01	02	03	04	05	06
3	SP	-	08	-	2X / H Q

1st spool axis

07	08	09	10	13	14
F	E	030-030	H2	Z	Z

2nd spool axis

07	08	09	10	11	13	14
F	E	030-030	P5	1	Q	H210

3rd spool axis

07	08	09	10	11	13	14
F	J	030-030	C2	1	S	S

End plate, additional information

15	16	17	18
LA	F	M	01

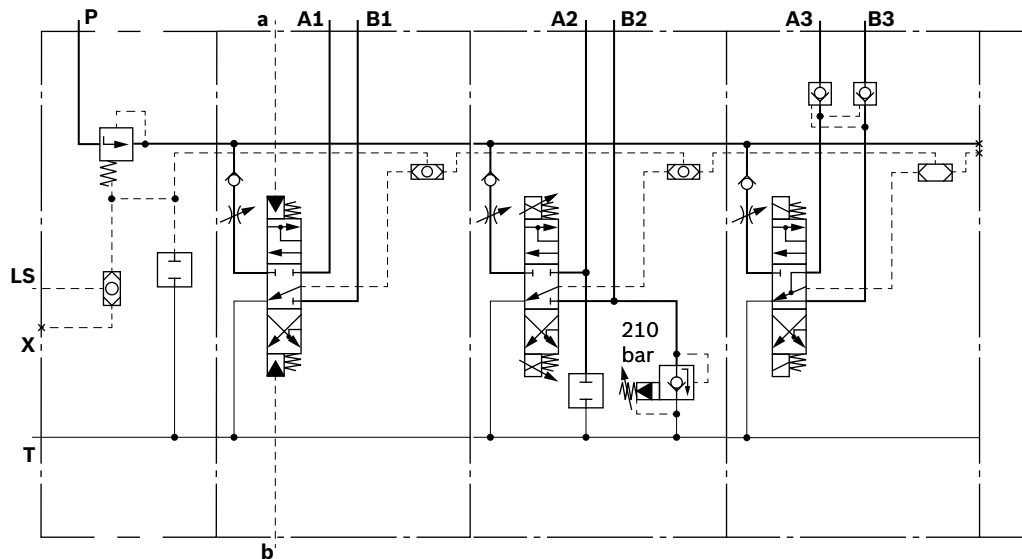

Open center inlet plates

Function with fixed displacement pump (open center)

When all of the directional valve axes are in the non-operated state, the pump flow is directed via the open center pressure compensator to the tank. If one directional valve axis is operated, the load pressure acts via the shuttle valve chain, which is now blocked to the tank, on the left-hand side of the pressure compensator and the pump-to-tank connection is interrupted. The highest actuator pressure acts in spring chamber (2) and on the left-hand side of pressure compensator spool (1).

The pump pressure acts on the right-hand side of this spool.

When the pump pressure rises to a value higher than the control pressure differential Δp plus actuator pressure, the pressure compensator spool is shifted to the left, and a part of the pump flow is directed to the tank until the balance is restored. The pressure in spring chamber (2) is limited by pressure relief valve (3). If the pressure rises further, the pressure compensator acts as main spool of a pilot operated pressure relief valve and limits the system pressure.

▼ Inlet plate P with 3-way pressure compensator

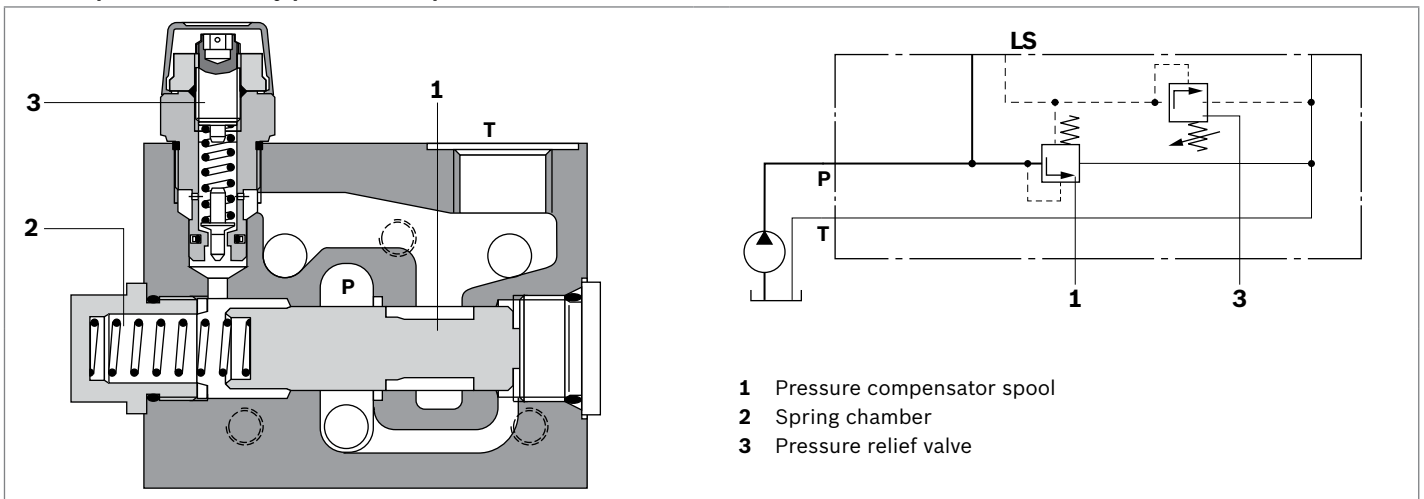

With 3-way pressure compensator

Ordering code:

SP	-	08	-	2X	/	P	Q
----	---	----	---	----	---	---	---

Short description

- ▶ For fixed displacement pump
- ▶ Primary pressure limitation function can be retrofitted
- ▶ Pressure limitation in the system required

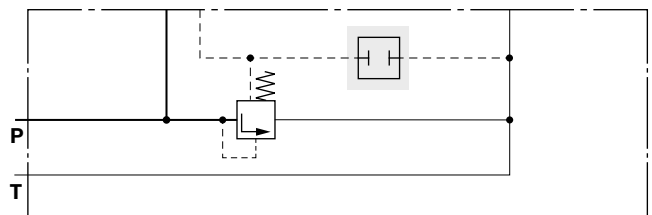

With 3-way pressure compensator

Ordering code:

SP	-	08	-	2X	/	P	...
----	---	----	---	----	---	---	-----

Short description

- ▶ For fixed displacement pump
- ▶ With primary pressure limitation function
- ▶ Pressure must be specified in bar (3-digit)

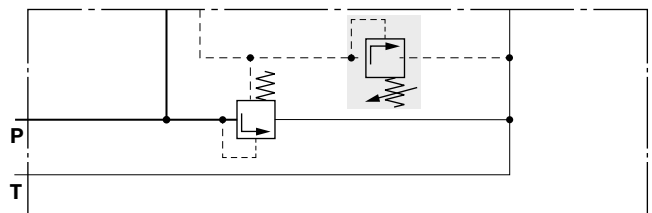

Closed center inlet plates

Function with variable displacement pump (closed center)

In the neutral position of the directional valve, the shuttle valve chain is unloaded. In the working positions, the load pressure of the actuator with the highest load acts in the LS port via the shuttle valve chain. The hardened shuttle valve seats can be replaced.

The LS port must be connected to the pressure/flow controller (DFR) of the pump. The controller maintains the pressure drop across the control block approximately constant over the entire operating range. The flow is therefore proportional to the cross-section opened by the spool between the pump and the actuator port in the course of the actuating operations – independent of the working pressure.

At the same time, the other actuator port is connected to the tank.

The relation between flow and spool travel, especially the maximum flow, can be adjusted on site to meet the individual requirements by means of an adjustable throttle that is combined with the load-holding valve.

When several actuators are operated simultaneously, the flow depends on the relevant pressure differential between pump pressure and load pressure.

The inlet plates can be fitted with 2-way pressure compensators, if further actuators are to be connected to a pump. In this case, the pressure compensator keeps the pressure differential across the directional valves constant.

Circuit examples

► Version J + G

- P** Pump
- A, B** Actuators
- LS** Load Sensing (LS)
- X** LS feed of an additional control block
- T** Tank

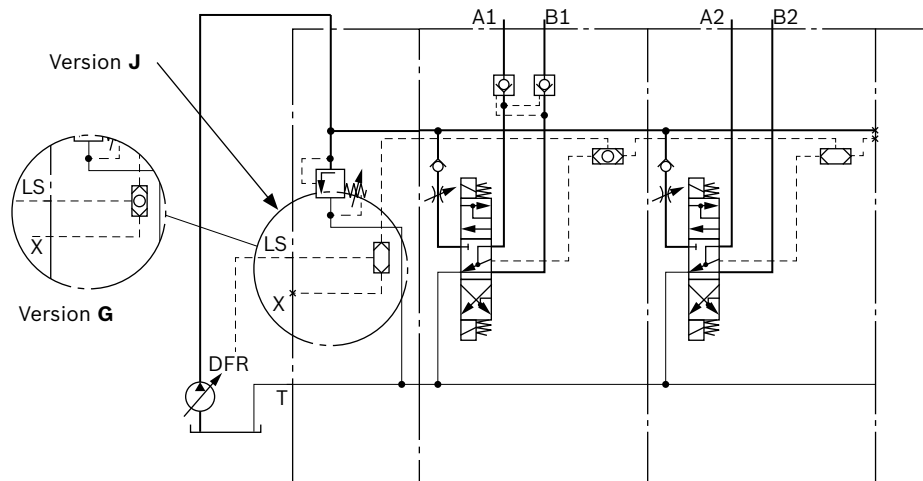

► Version H

Parallel connection of several control blocks

Project planning information for port "X"

LS pressure supply of an additional control block. With this version, a ball must be installed in the shuttle valve.

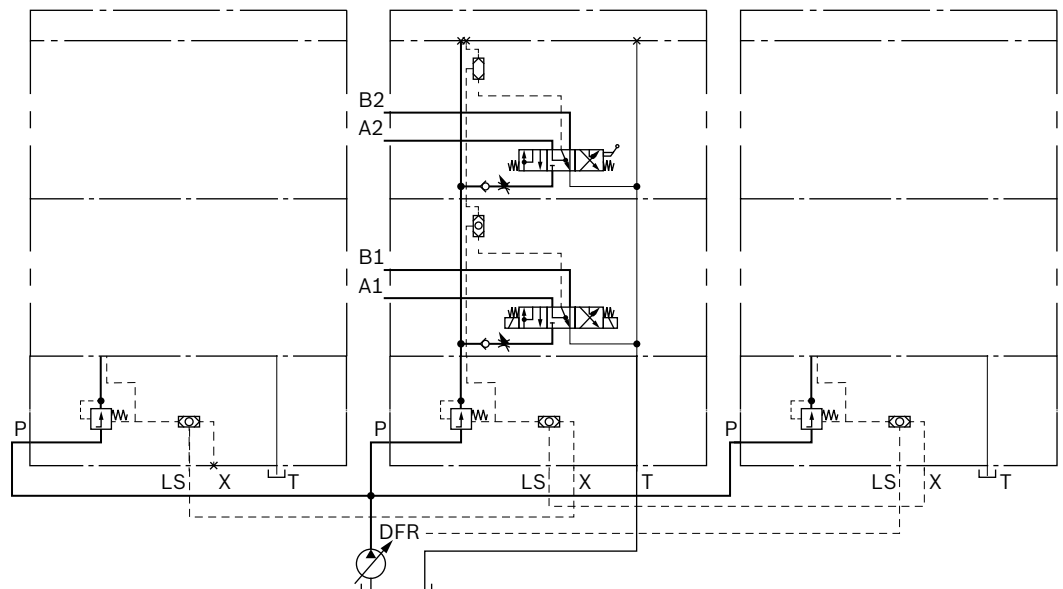

Without pressure compensator, without shuttle valve

Ordering code:

SP	-	08	-	2X	/	J	...
----	---	----	---	----	---	---	-----

Short description

- ▶ LS message to pump (DFR)
- ▶ With primary pressure limitation function
- ▶ Pressures must be specified in bar (3-digit)

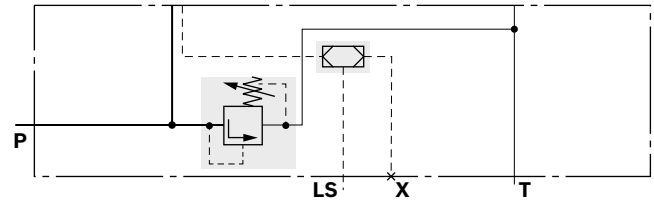

Without pressure compensator, with shuttle valve

Ordering code:

SP	-	08	-	2X	/	G	...
----	---	----	---	----	---	---	-----

Short description

- ▶ LS message to pump (DFR)
- ▶ LS supply of an additional control block at port X
- ▶ With primary pressure limitation function
- ▶ Pressure must be specified in bar (3-digit)

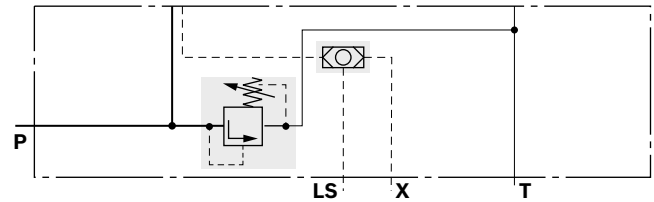

With 2-way pressure compensator, with shuttle valve

Ordering code:

SP	-	08	-	2X	/	H	...
----	---	----	---	----	---	---	-----

Short description

- ▶ LS message to pump (DFR)
- ▶ LS supply of an additional control block at port X
- ▶ With primary pressure cut-off
- ▶ Pressure must be specified in bar (3-digit)

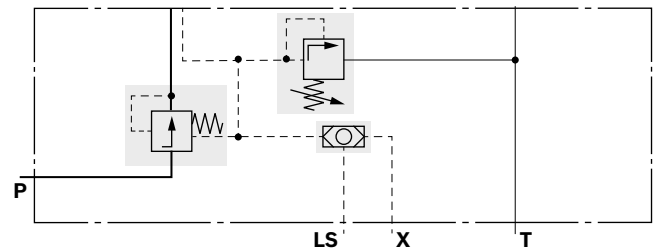

Without pressure compensator, without shuttle valve

Ordering code:

SP	-	08	-	2X	/	J	Q
----	---	----	---	----	---	---	---

Short description

- ▶ LS message to pump (DFR)
- ▶ Primary pressure limitation function can be retrofitted

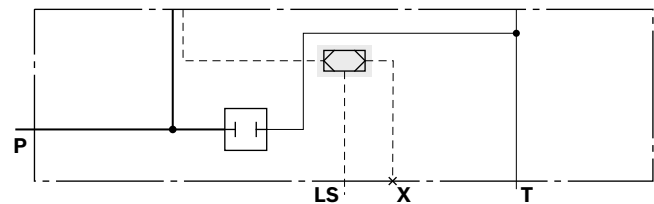

Without pressure compensator, with shuttle valve

Ordering code:

SP	-	08	-	2X	/	G	Q
----	---	----	---	----	---	---	---

Short description

- ▶ LS message to pump (DFR)
- ▶ LS supply of an additional control block at port **X**
- ▶ Primary pressure limitation function can be retrofitted

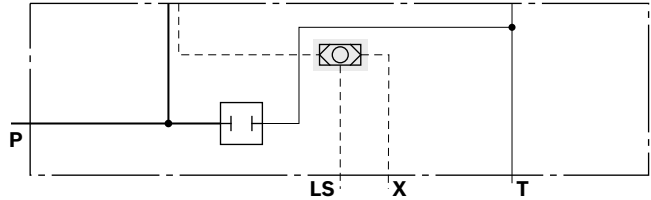

With 2-way pressure compensator, with shuttle valve

Ordering code:

SP	-	08	-	2X	/	H	Q
----	---	----	---	----	---	---	---

Short description

- ▶ LS message to pump (DFR)
- ▶ LS supply of an additional control block at port **X**
- ▶ Primary pressure limitation function can be retrofitted

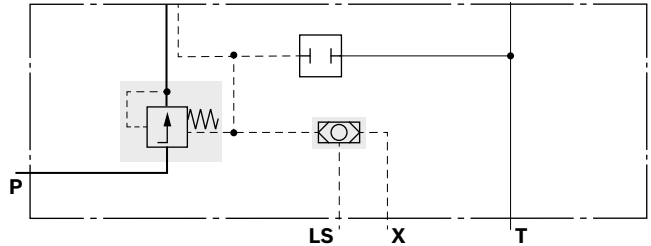

With priority valve

Ordering code:

SP	-	08	-	2X	/	V	...
----	---	----	---	----	---	---	-----

Short description

- ▶ Internal priority function, external subordinate actuators (port C)
- ▶ With primary pressure limitation function
- ▶ Pressure must be specified in bar (3-digit)
- ▶ LS message to flow-controlled pump (port **X**)

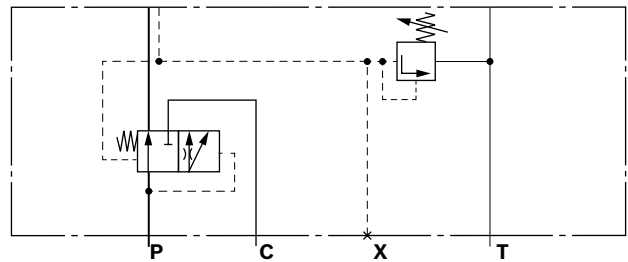

Adapter plate for M4-12 directional valves

Ordering code:

SP	-	08	-	2X	/	L8	210
----	---	----	---	----	---	----	-----

Short description

- ▶ With integrated 2-way pressure compensator
- ▶ With LS pressure relief valve, set to 210 bar
- ▶ Type code for flanged M4-12 directional valves according to data sheet 64276
- ▶ Up to 7 M4-12 directional valves are admissible

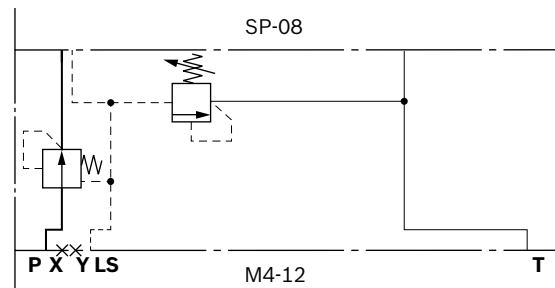

Directional valves

Pressure compensator spool

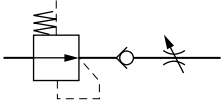
Ordering code	Short description	Symbol
F	Variable orifice with load holding function	
S	Section pressure compensator and variable orifice with load holding function	

Main spool

The flow is dependent on the type of actuation and the Δp of the pressure compensator.

▼ Spool type E

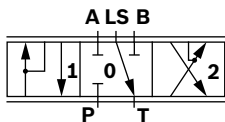

▼ Spool type J

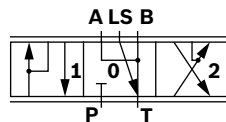

Preferred types (spool types E, J)

Flow in l/min	
Symmetric spool valves	Asymmetric spool valves
010-010	010-020
020-020	020-040
030-030	
040-040	

Types of actuation

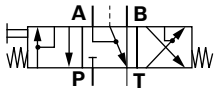
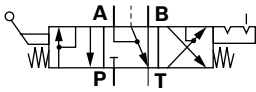
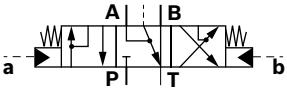
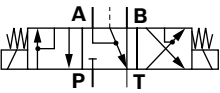
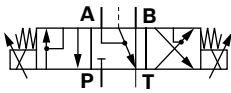
Mechanical – spool end with tongue Z1 A A2 	Mechanical – encapsulated lever R5 A B2 
Hydraulic H2 	
Electro-magnetically switchable, without secondary valve C2 	Electro-magnetically proportional, without secondary valve P5 

Secondary valves

With plug screw and pressure relief/anti-cavitation valve

Ordering code:

S	J	030-030	C2	1	Q	H210
---	---	---------	----	---	---	------

Short description

- ▶ Plug screw on actuator port A, secondary valves can be retrofitted
- ▶ Pressure relief/anti-cavitation valve on actuator side B, permanently set to 210 bar

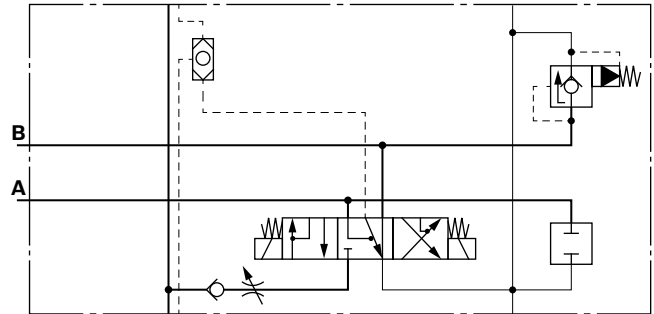

▼ **Preferred pressure settings for pressure relief valves with anti-cavitation function**

Pressure settings in bar in actuator ports A and B			
H050 = 50 bar	H125 = 125 bar	H175 = 175 bar	H280 = 280 bar
H063 = 63 bar	H140 = 140 bar	H190 = 190 bar	H300 = 300 bar
H080 = 80 bar	H150 = 150 bar	H210 = 210 bar	H240 = 240 bar
H100 = 100 bar	H160 = 160 bar	H230 = 230 bar	H250 = 250 bar

Notice
Pressure valve settings are fixed!
Adjustable pressure valves upon request.

With pilot operated check valves

Ordering code:

F	J	030-030	C2	1	S	S
---	---	---------	----	---	---	---

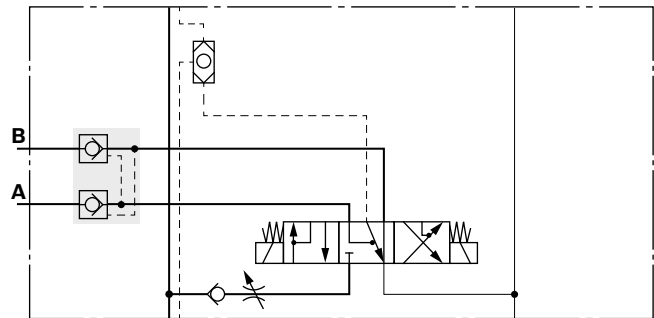

With 1 pilot operated check valve

Ordering code:

F	J	030-030	C2	1	Z	S
---	---	---------	----	---	---	---

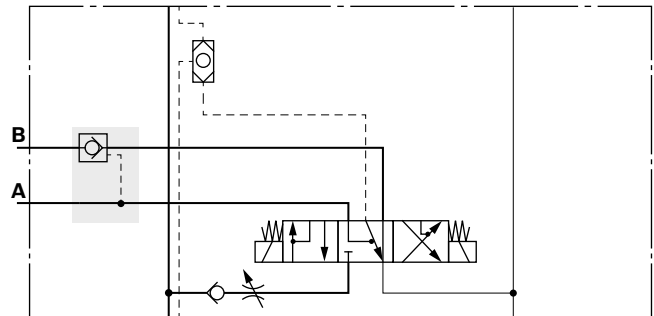

Electro-magnetically switchable, with float function with hydraulic detent

Ordering code:

F	J	030-030	C2	1	A	Z
---	---	---------	----	---	---	---

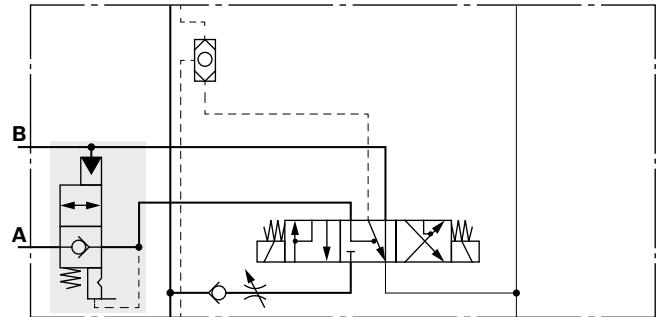

Electro-magnetically switchable, with pilot operated check valves with split opening spool

Ordering code:

F	J	030-030	C2	1	B	B
---	---	---------	----	---	---	---

Short description

- Only in connection with end plate **SV**

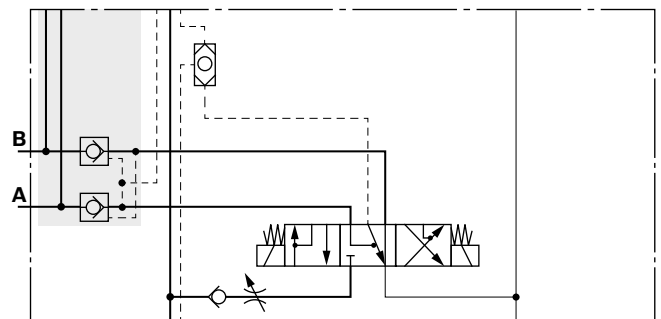

End plates

Without function

Ordering code:

LA

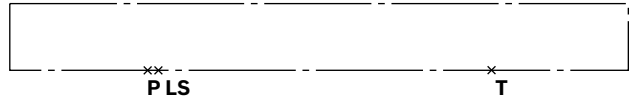

End plate with LS port

Ordering code:

LS

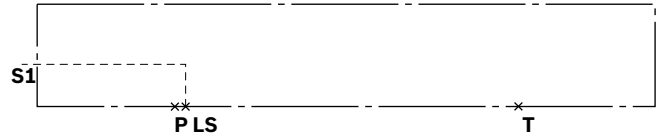

End plate with internal tank connection

Ordering code:

LU

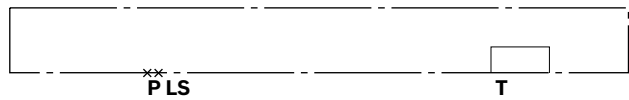

End plate with seat valve

Ordering code:

SV

Short description

- Only in connection with directional valve **BB**

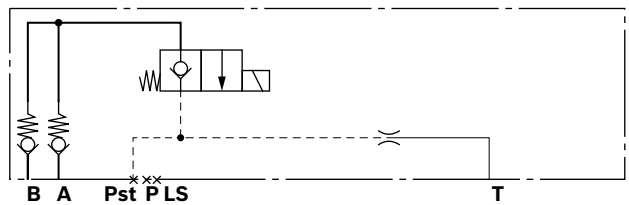

Line connections

Connections as pipe threads according to ISO 228/1

Port	
P	G 3/8
T	G 1/2
A, B	G 3/8
LS	G 1/4
X	G 1/4
a, b	G 1/4

d1	Ø d2	t1	t2
G 3/8	28	12	0.5
G 1/4	25	12	0.5
G 1/2	34	14	0.5

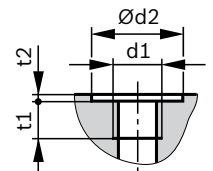

Dimensions

Inlet plates

▼ Open Center

Ordering code:

P

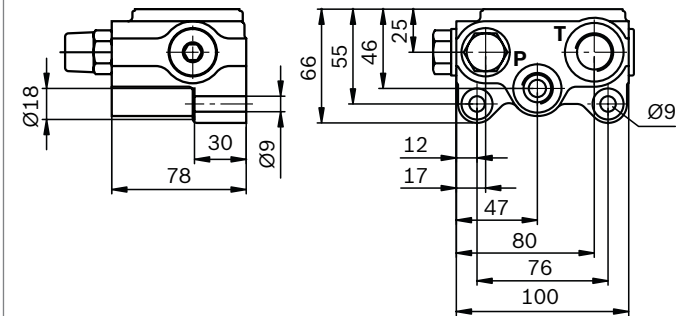

▼ Closed Center

Ordering code:

J , **G**

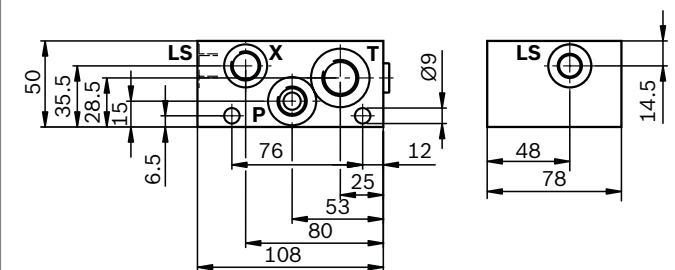

▼ Closed Center

Ordering code:

H

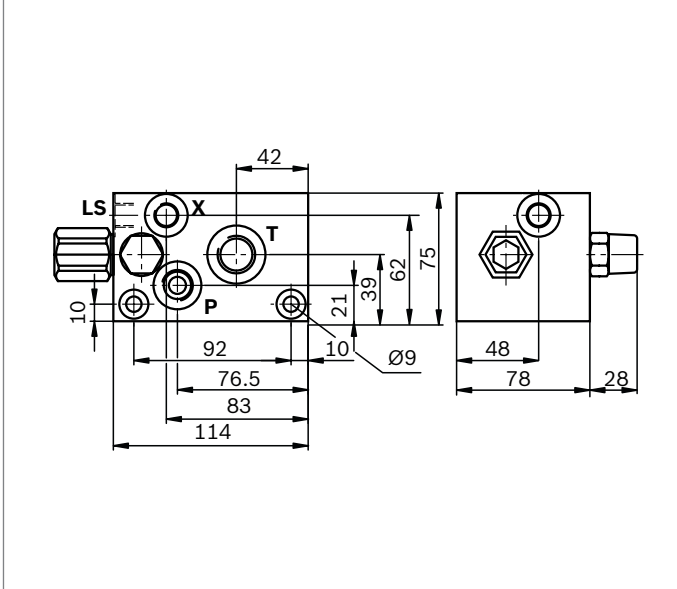

▼ Priority valve

Ordering code:

V

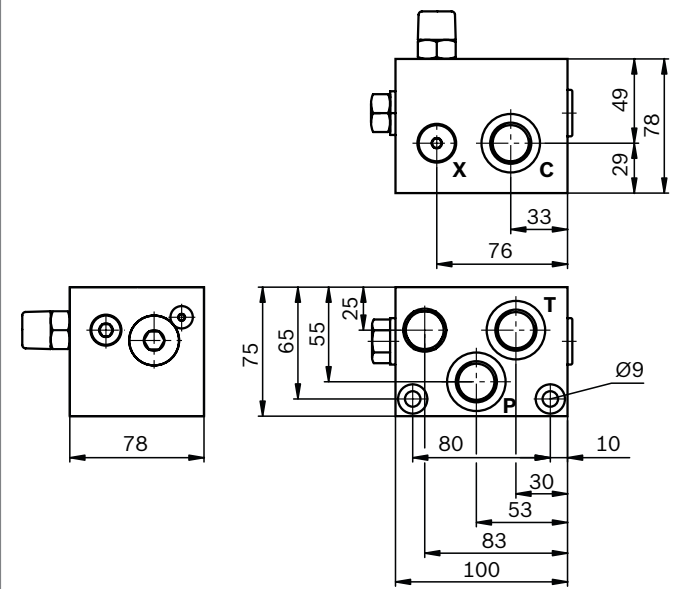

Types of actuation

▼ **Mechanical operation, spool end with tongue**

Ordering code:

...	Z1	B	B2	...
...	Z1	B	C2	...
...	Z1	B	D2	...

Side A

Side B

▼ **Mechanical operation, encapsulated lever**

Ordering code:

...	R5	B	A2	...
-----	----	---	----	-----

Notice
Other hand lever positions are possible.

▼ **Mechanical operation, 2-axis lever**

Ordering code:

R9

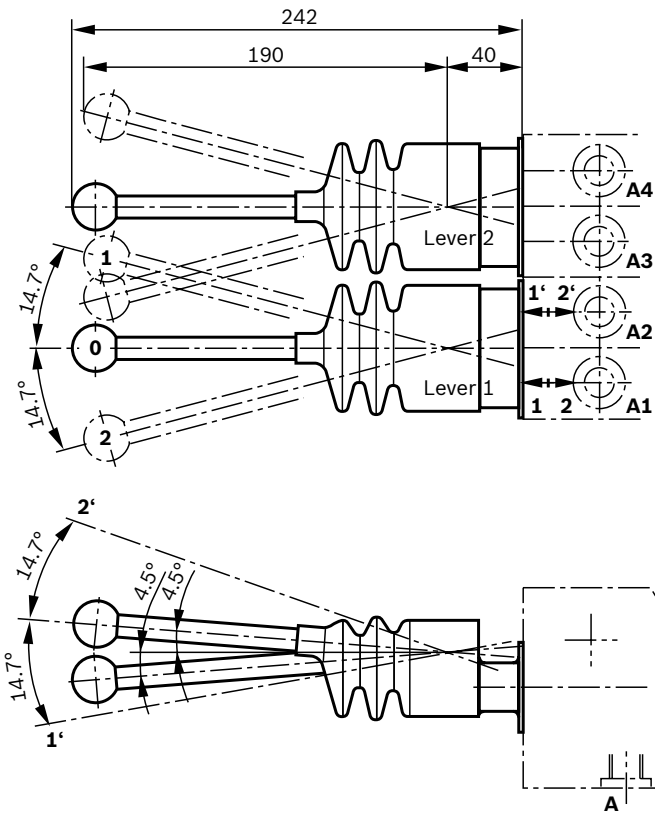

Notice

Parallel operation of lever 1 and lever 2 is restricted in the overlap area.

▼ **Hydraulic actuation**

Ordering code:

H2

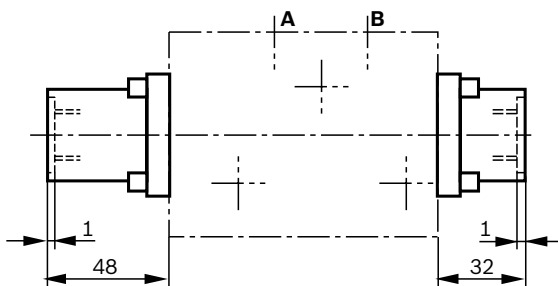

▼ **Electro-magnetically switchable actuation**

Ordering code:

C2

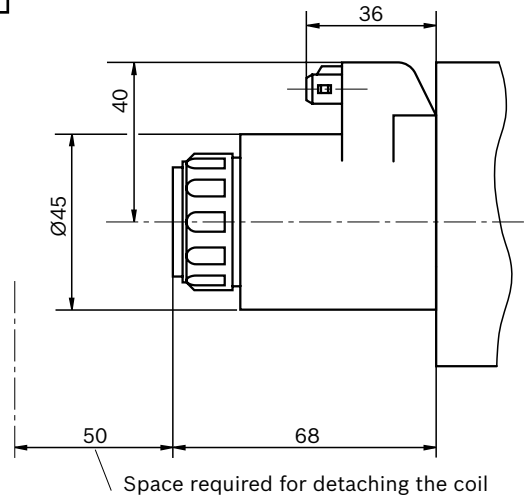

Notice

Both terminals must be wired for of each solenoid.

▼ **Electro-magnetic proportional actuation**

Ordering code:

P5

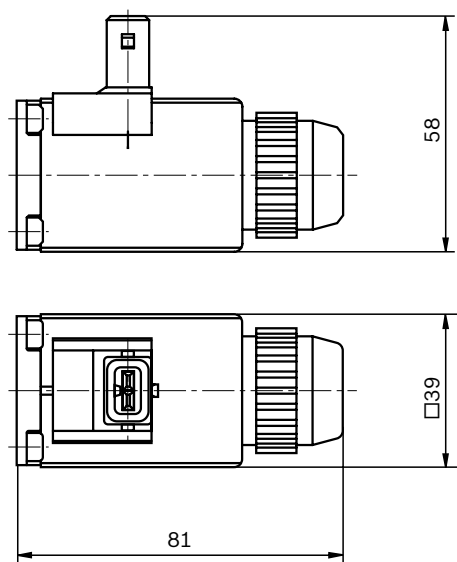

End plates

▼ **Without function, with mounting bracket**

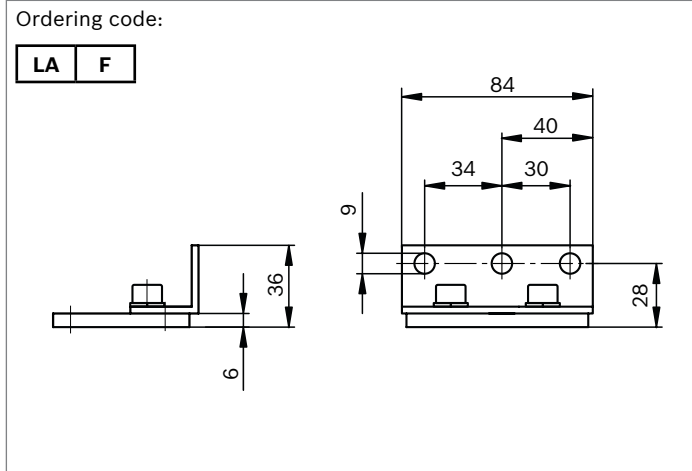

▼ **With LS connection, without mounting bracket**

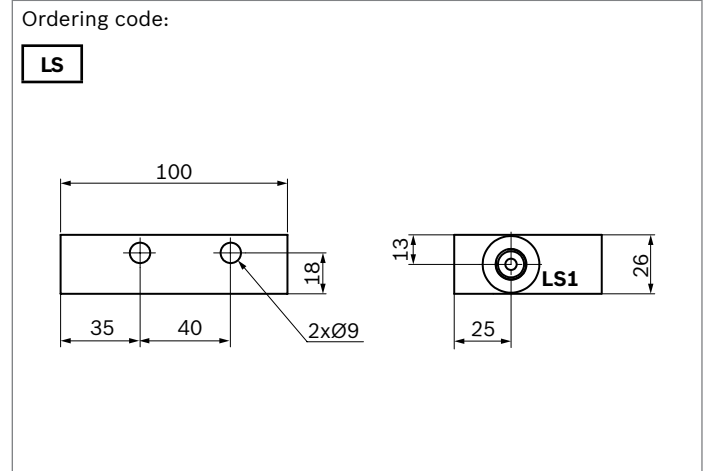

▼ **With internal tank connection, with mounting bracket**

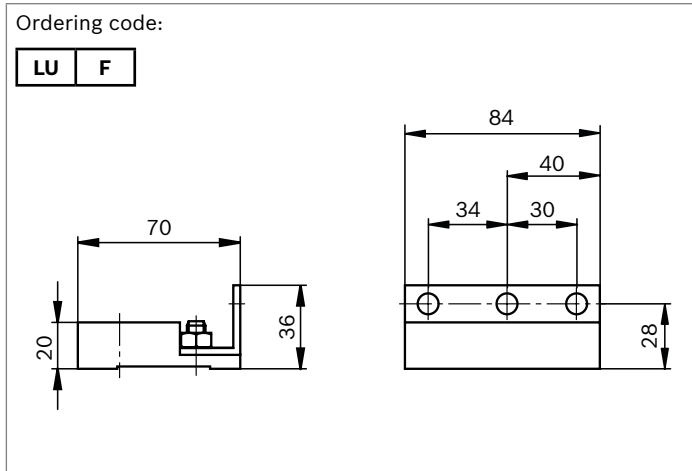

▼ **With seat valve**

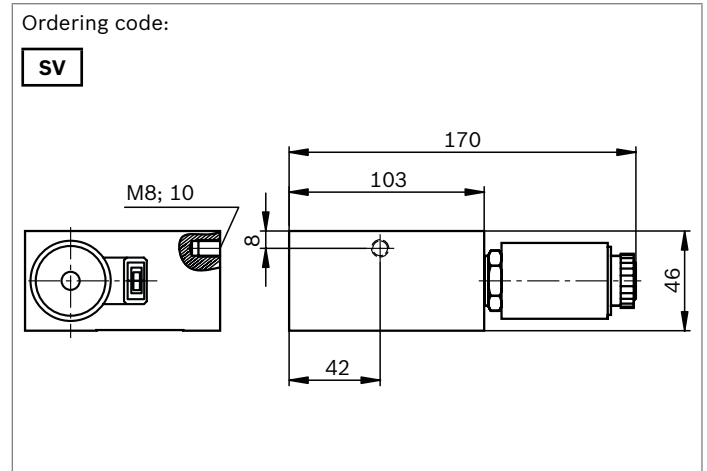

▼ **Adapter plate for M4-12 directional valves**

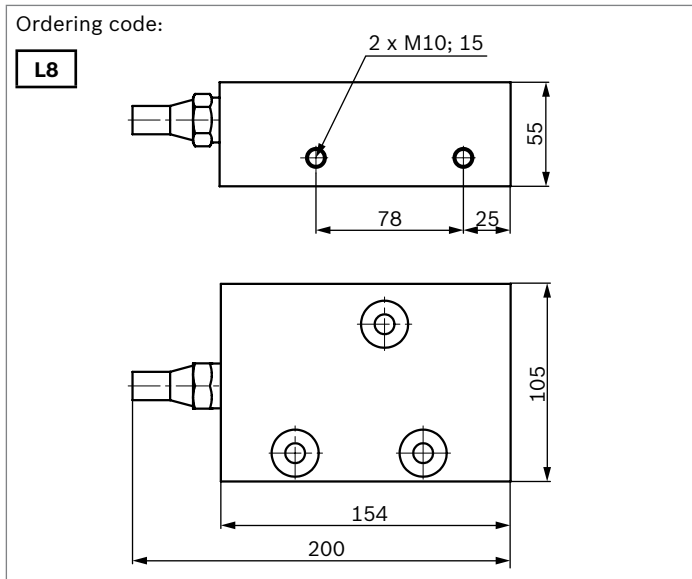

Order examples

▼ **Open center control block of sandwich plate design** (according to order example on page 9)

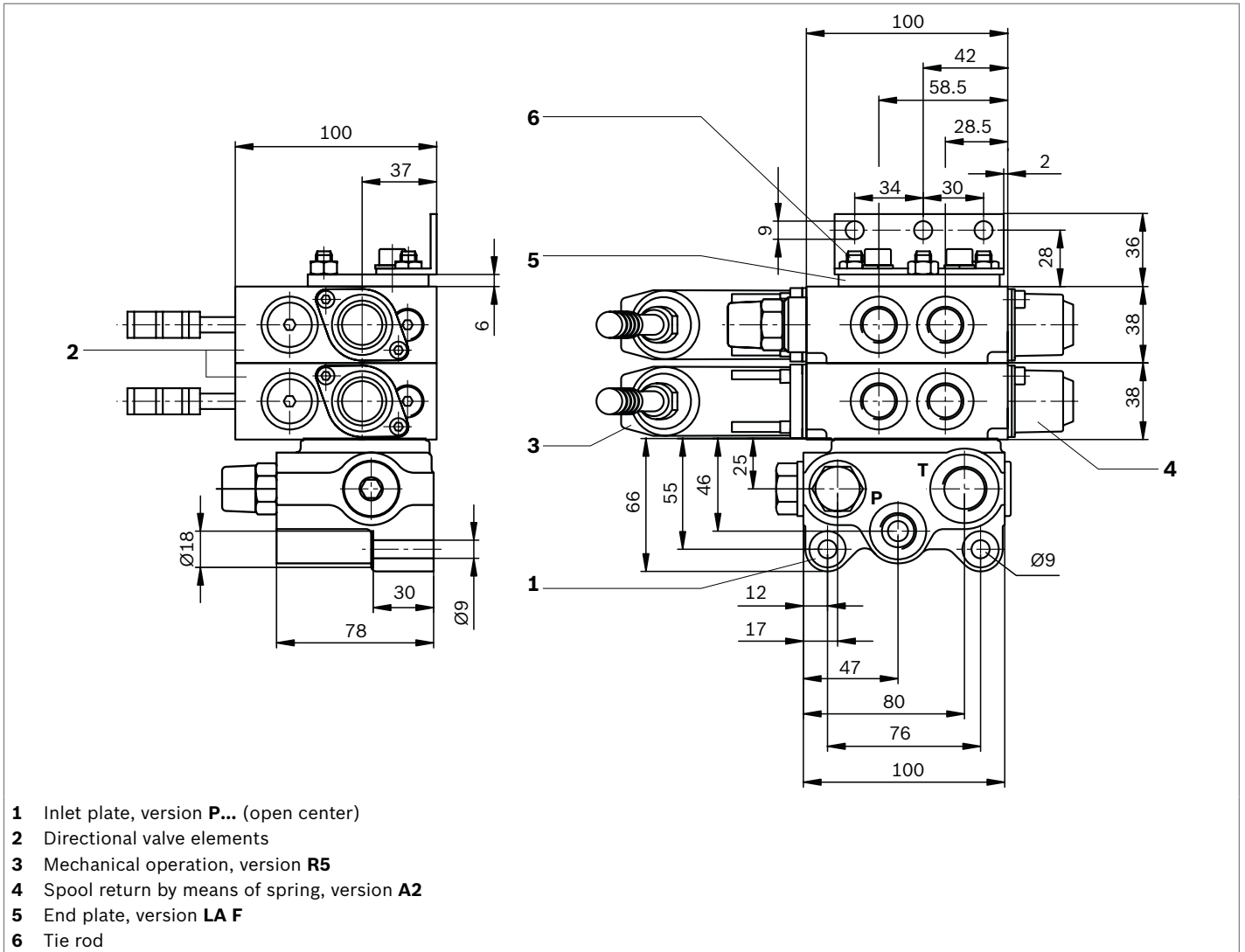

▼ **Closed center control block of sandwich plate design** (according to order example on page 10)

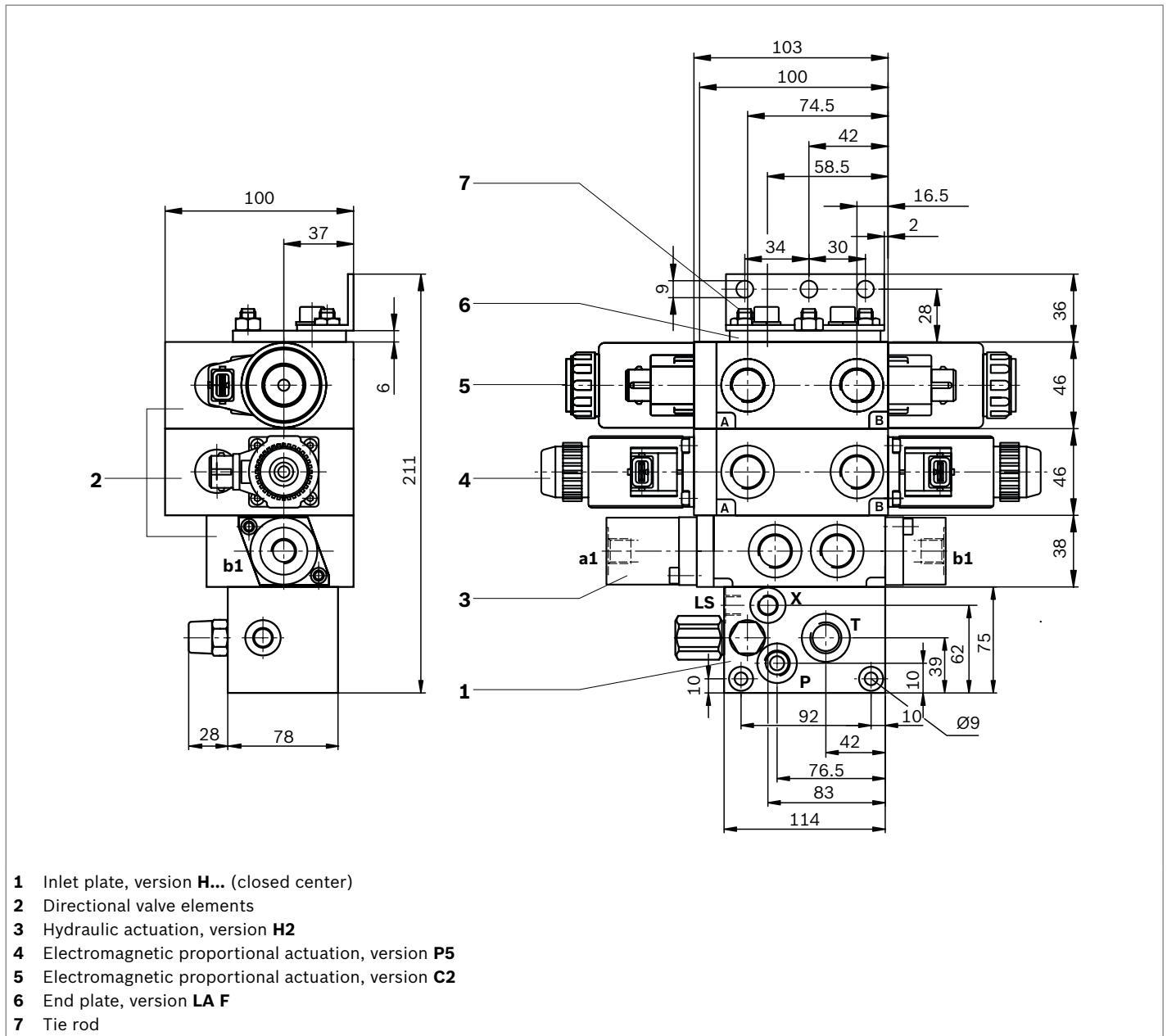

Accessories

Recommended mating connector for plug-in connector, type Junior Timer 2-pole (AMP)

Mating connector for FTDRE... and FTWE... protection class IP 69K

- ▶ **Material number: R900313533**
for litz wire cross-sections of 0.5 to 1 mm² and for an insulation diameter of the individual sealings of 1.2 to 2.1 mm
- ▶ **Material number: R901022127**
for litz wire cross-sections of 0.5 to 1 mm² and for an insulation diameter of the individual sealings of 2.2 to 3 mm

▼ Recommended mating connector for Junior Timer, 2-pole (AMP)



Notice

Mating connectors are not included in the scope of delivery and must be ordered separately.

Bosch Rexroth AG

Mobile Applications
Zum Eisengießer
97816 Lohr am Main, Germany
Phone +49 9352 18-0
info.ma@boschrexroth.de
www.boschrexroth.com

© This document, as well as the data, specifications and other information set forth in it, are the exclusive property of Bosch Rexroth AG. It may not be reproduced or given to third parties without its consent.

The data specified above only serve to describe the product. No statements concerning a certain condition or suitability for a certain application can be derived from our information. The information given does not release the user from the obligation of own judgment and verification. It must be remembered that our products are subject to a natural process of wear and aging.